



DESCRIPTION:

The JST08K-600BW triac is suitable for general purpose AC switching. It can be used as an ON/OFF function in applications such as heating regulation, induction motor starting circuits, for phase control operation in light dimmers, motor speed controllers. JST08K-600BW snubberless triac is especially recommended for use on inductive loads. Package TO-252 is RoHS compliant.

MAIN FEATURES

Symbol	Value	Unit
$I_{T(RMS)}$	8	A
V_{DRM}/V_{RRM}	600	V
$I_{GT} / /$	60/50/50	

ABSOLUTE MAXIMUM RATINGS

Parameter	Symbol	Value	Unit
Storage junction temperature range	T_{stg}	-40-150	
Operating junction temperature range	T_j	-40-125	
Repetitive peak off-state voltage ($T_j=25^\circ C$)	V_{DRM}	600	V
Repetitive peak reverse voltage ($T_j=25^\circ C$)	V_{RRM}	600	V
RMS on-state current ($T_c 091^\circ C$)	$I_{T(RMS)}$	8	A
Non repetitive surge peak on-state current (full cycle, $t_p=20ms$, $T_j=25^\circ C$)	I_{TSM}	80	A
Non repetitive surge peak on-state current (full cycle, $t_p=16.6ms$, $T_j=25^\circ C$)		88	
I^2t value for fusing ($t_p=10ms$, $T_j=25^\circ C$)	I^2t	32	A^2s
Critical rate of rise of on-state current ($I_G=2 \times I_{GT}$, $f=100Hz$, $T_j=125^\circ C$)	di/dt	100	A/s
Peak gate current ($t_p=20\mu s$, $T_j=125^\circ C$)	I_{GM}	4	A
Average gate power dissipation ($T_j=125^\circ C$)	$P_{G(AV)}$	0.5	W
Peak gate power	P_{GM}	10	W

Peak pulse voltage ($T_j=25$; non-repetitive, off-state; FIG.8)	V_{pp}	2.5	kV
--	----------	-----	----

ELECTRICAL CHARACTERISTICS (unless otherwise specified)

Symbol	Test Condition	Quadrant	Value		Unit
I_{GT}	$V_D=12V R_L=33$	- -	MAX.	50	mA
V_{GT}		- -	MAX.	1	V
V_{GD}	$V_D=V_{DRM} T_j=125$ $R_L=3.3k$	- -	MIN.	0.2	V
I_L	$I_G=1.2I_{GT}$	-	MAX.	50	mA
				90	
I_H	$I_T=100mA$		MAX.	50	mA
dV/dt	$V_D=400V$ Gate Open $T_j=125$		MIN.	2000	V/s
(dI/dt) _c	(dV/dt) _c =20V/s, $T_j=125$		MIN.	12	A/ms
t_{on}	$I_G=80mA I_A=400mA I_R=40mA$ $T_j=25$		TYP.	5	s
t_{off}				50	

STATIC CHARACTERISTICS

Symbol	Parameter		Value(MAX.)	Unit
V_{TM}	$I_{TM}=11A t_p=380 \mu s$	$T_j=25$	1.5	V
V_{TO}	Threshold voltage	$T_j=125$	0.8	V
R_D	Dynamic resistance	$T_j=125$	44	m
I_{DRM}	$V_D=V_{DRM} V_R=V_{RRM}$	$T_j=25$	5	A
I_{RRM}		$T_j=125$	0.25	mA

THERMAL RESISTANCES

JST08K-600BW

FIG.7: Relative variations of gate trigger current, holding current and latching current versus junction temperature

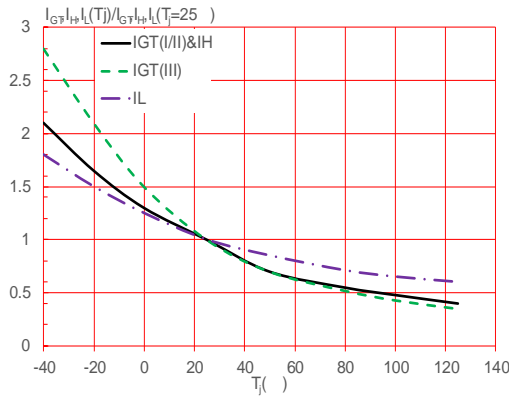
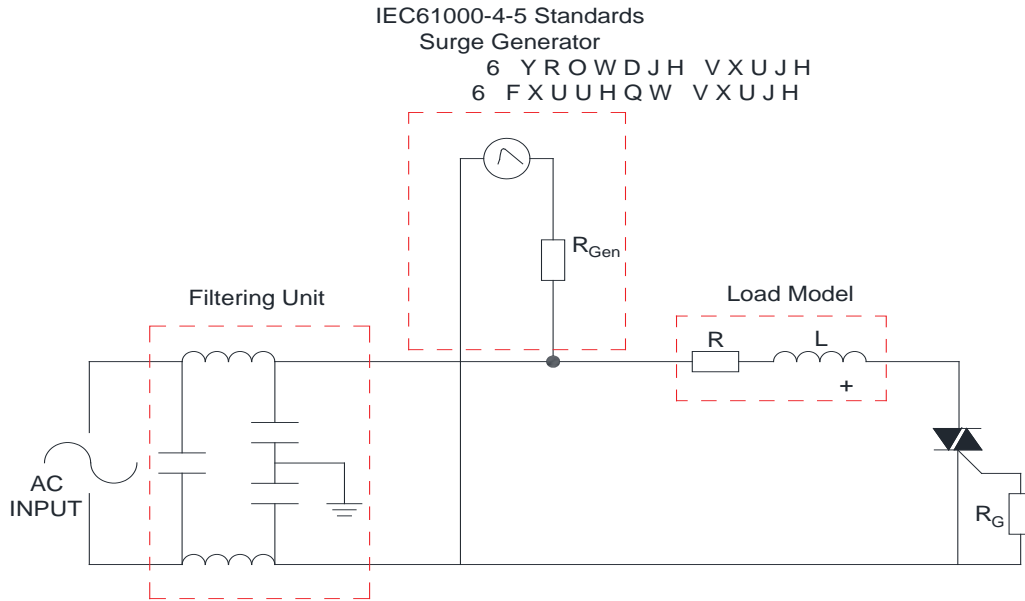

FIG.8 ÖTest circuit for inductive and resistive loads to IEC-61000-4-5 standards



ORDERING INFORMATION

Order code	Voltage V_{DRM}/V_{RRM} (V)	IGT(mA)	Package	Base qty. (pcs)	Delivery mode
		- -			
JST08K-600BW	600	50	TO-252	80	Tube
JST08K-600BW-TR				2,500	Tape & Reel

Document Revision History

Date	Revision	Changes
Apr.12, 2023	A.1	

PACKAGE MECHANICAL DATA

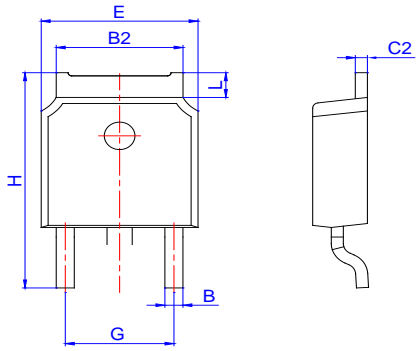

Ref.	Dimensions					
	Millimeters			Inches		
	Min.	Typ.	Max.	Min.	Typ.	Max.
A	2.10		2.50	0.083		0.098
A2	0		0.15	0		0.006
B	0.66		0.86	0.026		0.034
B2	5.18		5.48	0.202		0.216
C	0.40		0.60	0.016		0.024
C2	0.44		0.58	0.017		0.023
D	5.90		6.30	0.232		0.248
D1						
E	6.40		6.80	0.252		0.268
E1	4.63			0.182		
G	4.47		4.67	0.176		0.184
G1	2.18		2.38	0.086		0.094
L	1.09		1.21	0.043		0.048
L2	1.35		1.65	0.053		0.065



LIVERY MODE

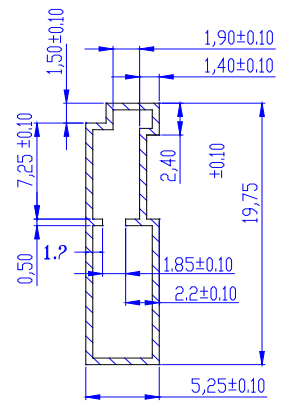

Information furnished in this document is believed to be accurate and reliable. However, Jiangsu JieJie Microelectronics Co., Ltd. assumes no responsibility for the consequences of use without consideration for such information nor use beyond it. Information mentioned in this document is subject to change without notice, apart from that when an agreement is signed, Jiangsu JieJie complies with the agreement.

Products and information provided in this document have no infringement of patents.

Jiangsu JieJie assum12 (n)1(j)6.1 (ec)4 (t)0 (ec)4 (4 (i)6 (bi)6 (l)6 (i)6 (t)2 (y)14 (f)2 (or)6.9 (t-