



## JST08H-800C 8A TRIAC

Rev.A.1.1

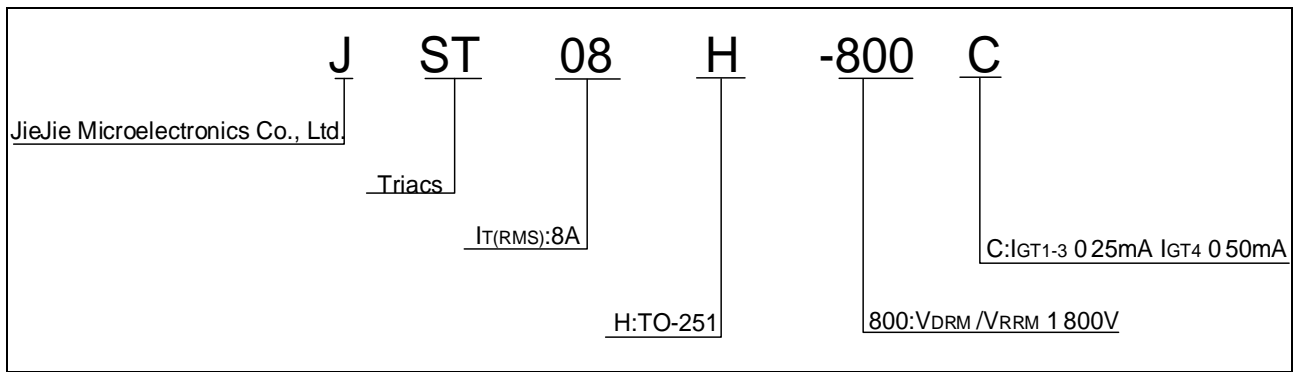
### DESCRIPTION:

The JST08H-800C triac is suitable for general purpose AC switching. It can be used as an ON/OFF function in applications such as heating regulation, induction motor starting circuits, á M /N o4

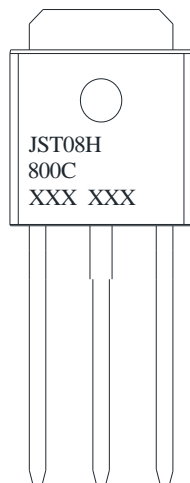
ELECTRICAL CHARACTERISTICS ( $T_j=25$  unless otherwise specified)

Symbol	Test Condition	Quadrant	Value		Unit
$I_{GT}$	$V_D=12V$ $R_L=33$	- -	MAX.	25	mA
				50	
$V_{GT}$		ALL	MAX.	1	V
$V_{GD}$	$V_D=V_{DRM}$ $T_j=125$ $R_L=3.3k$	ALL	MIN.	0.2	V
$I_L$	$I_G=1.2I_{GT}$	- -	MAX.	40	mA
				80	
$I_H$	$I_T=200mA$		MAX.	30	mA
$dV/dt$	$V_D=540V$ Gate Open $T_j=125$		MIN.	500	V/ $\mu s$
$(dV/dt)_c$	$(dI/dt)_c=3.5A/ms$ , $T_j=125$		MIN.	6	V/ $\mu s$
$t_{on}$ $t_{off}$	$I_G=80mA$ $I_A=400mA$ $I_R=40mA$ $T_j=25$		TYP.	5	$\mu s$

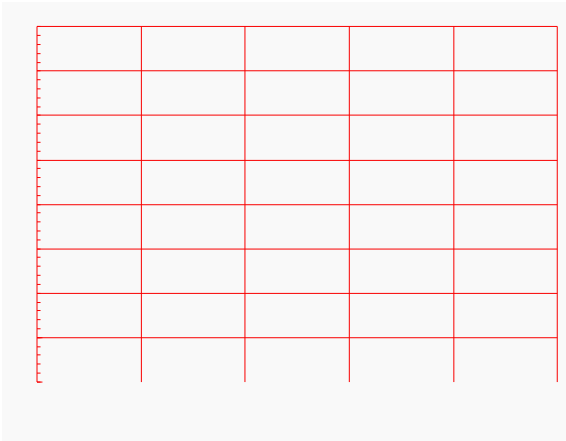
## ORDERING INFORMATION



## MARKING

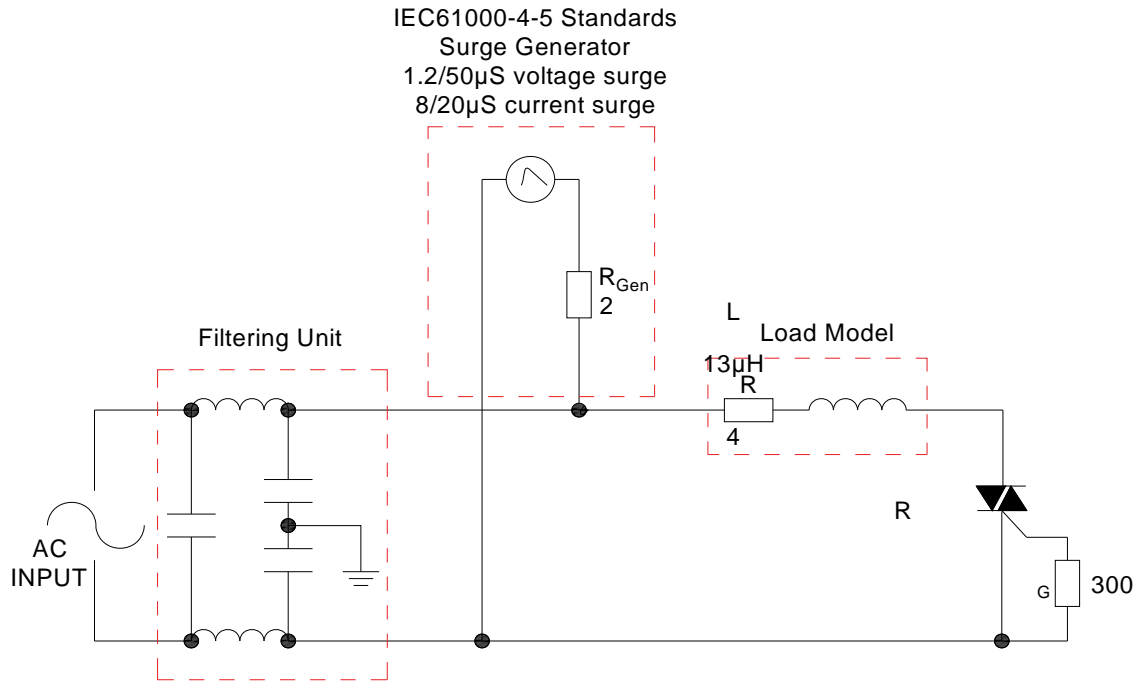


**FIG.1:** Maximum power dissipation versus RMS on-state current



**FIG.2:** RMS on-state current versus case temperature

FIG.7 ÖTest circuit for inductive and resistive loads to IEC-61000-4-5 standards



## LEAD FORMING AND SOLDERING

Refer to the application note “Assembly Instructions for Thyristors in Through-hole Package” released by JieJie D ] Œ } o š Œ } v ] •

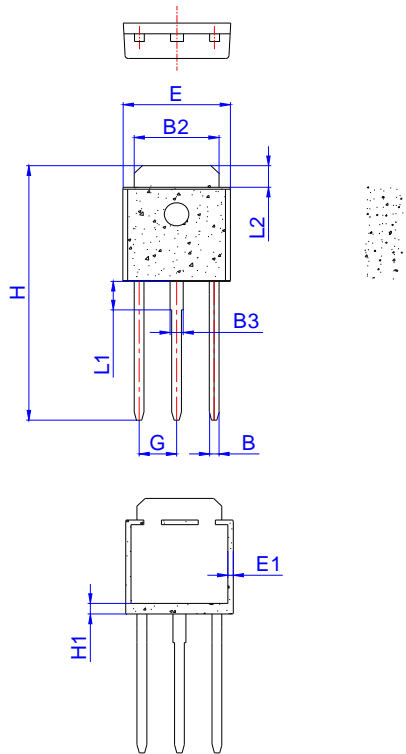
## ORDERING INFORMATION

Order code	Voltage $V_{DRM}/V_{RRM}$ (V)	IGT(mA)		Package	Base qty. (pcs)	Delivery mode
		-	-			
JST08H-800C	800	25	50	TO-251	80	Tube

## Document Revision History

Date	Revision	Changes
Apr.14, 2023	A.1.0	Last updated
Oct.24, 2025	A.1.1	Revise PACKAGE MECHANICAL DATA


PACKAGE MECHANICAL DATA



Ref.	Dimensions					
	Millimeters			Inches		
	Min.	Typ.	Max.	Min.	Typ.	Max.
A	2.20		2.40	0.086		0.095
A2	1.00		1.30	0.039		0.051
B	0.50		0.70	0.020		0.028
B2	5.10		5.40	0.200		0.213
B3						
C						
C2						
D						
E						
E1	0.60		1.00	0.024		0.039
G						
H	16.00		17.00	0.630		0.669
H1	1.45		1.85	0.057		0.073
L1						

Information furnished in this document is believed to be accurate and reliable. However, Jiangsu JieJie Microelectronics Co., Ltd assumes no responsibility for the consequences of use without consideration for such information nor use beyond it. Information mentioned in this document is subject to change without notice, apart from that when an agreement is signed, Jiangsu JieJie complies with the agreement.

Products and information provided in this document have no infringement of patents. Jiangsu JieJie assumes no responsibility for any infringement of other rights of third parties which may result from the use of such products and information. This document supersedes and replaces all information previously supplied.

 is a registered trademark of Jiangsu JieJie Microelectronics Co., Ltd.  
Copyright © 2025 Jiangsu JieJie Microelectronics Co., Ltd. All rights reserved.