

2 Mode 2

The chip uses common power supply mode, when the ZCD is grounded, the chip shields the zero-crossing detection function, and the GATE driver signal is only controlled by the EN signal. When the EN signal output by the MCU to the chip is high, the GATE will output the drive signal (6 cycles of 200us, square wave with 50% duty cycle) and trigger the thyristor work. In order to ensure the full turn-on of the thyristor, the high level maintenance time of the EN is at least longer than the drive signal time of the GATE. When the MCU output EN signal is low, the GATE will stop

3 Mode 3

The chip uses common power supply mode, ZCD is connected to AC power line or load terminal through resistance. The pin is used for zero-crossing detection. When the chip detection crosses the ZERO, ZERO outputs the zero-crossing signal to the MCU. According to the zero-crossing signal provided by the chip, the MCU can output the EN high level enable signal immediately or after the corresponding delay, and feed back to the chip. At this time, the GATE end of the chip outputs the drive signal (6 cycles of 200us, square wave with 50% duty cycle) and trigger the thyristor work. In order to ensure the full turn-on of the thyristor, the high level maintenance time of the EN is at least longer than the drive signal time of the GATE. When the MCU output EN signal is low, the GATE will stop

TYPICAL APPLICATION CIRCUIT

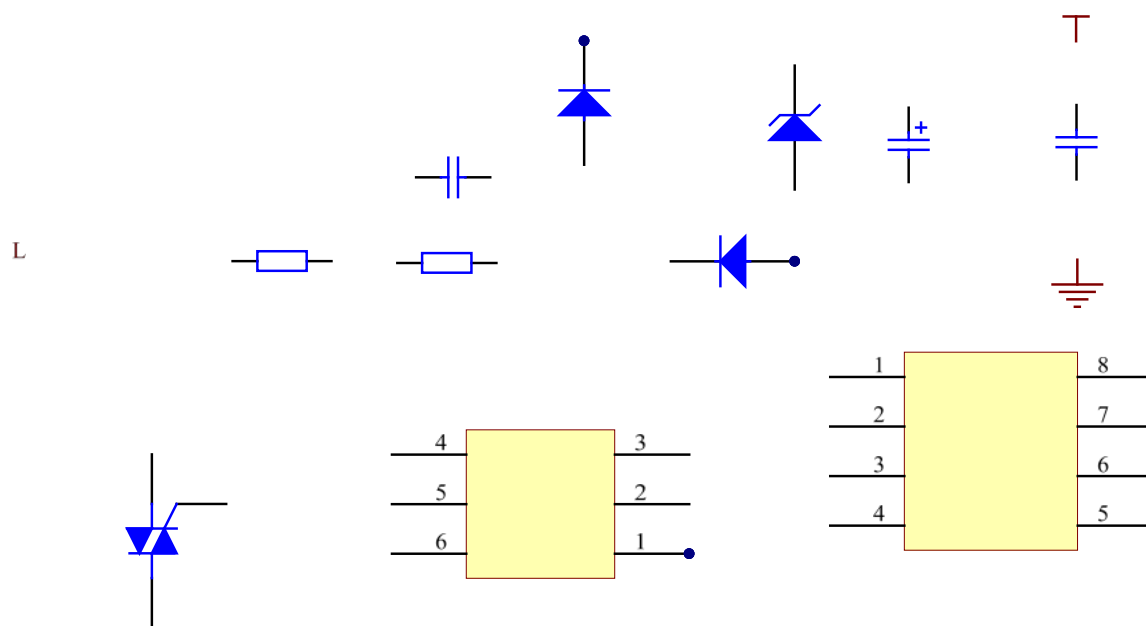

NAMING RULE

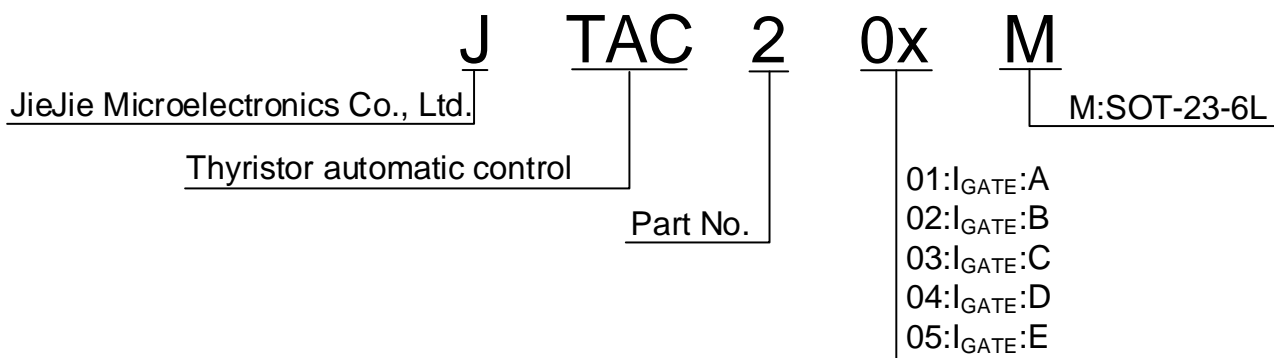

MARKING

Note: "X" is marked according to the current gear of the GATE actually produced.

ORDERING INFORMATION

Order code	I _{GATE}	Package	Base qty. (pcs)	Delivery mode	MPQ (pcs)	MOQ (pcs)
JTAC201M	A	SOT23-6L	3,000	Tape and Reel	30,000	120,000
JTAC202M	B	SOT23-6L	3,000	Tape and Reel	30,000	120,000
JTAC203M	C	SOT23-6L	3,000	Tape and Reel	30,000	120,000
JTAC204M	D	SOT23-6L	3,000	Tape and Reel	30,000	120,000
JTAC205M	E	SOT23-6L	3,000	Tape and Reel	30,000	120,000

Document Revision History

Date	Revision	Changes
May.07, 2023	1.0	Last update

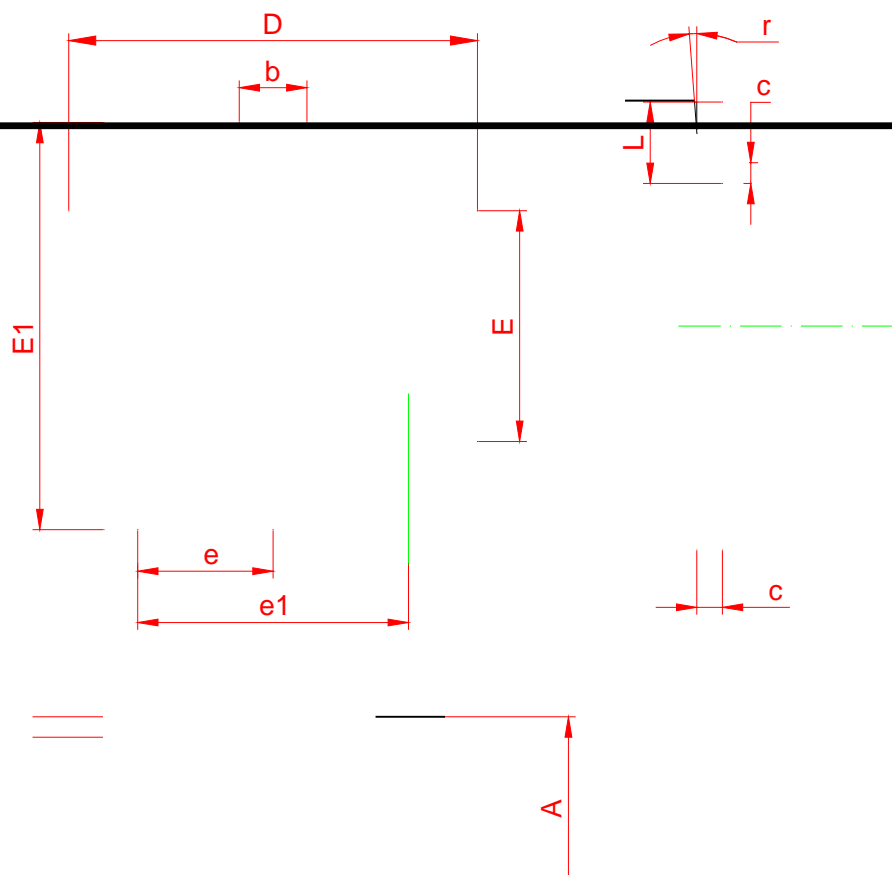
PACKAGE MECHANICAL DATA

Symbol	Dimensions In Millimeters		Dimensions In Inches	
	Min.	Max.	Min.	Max.
A	1.000	1.300	0.039	0.051
A1	0.000	0.150	0.000	0.006
A2	1.000	1.200	0.039	0.047
b	0.300	0.500	0.012	0.020
c	0.100	0.200	0.004	0.008
D	2.800	3.020	0.110	0.119
E	1.500	1.700	0.059	0.067
E1	2.600	3.000	0.102	0.118
e	0.950 (BSC)		0.037 (BSC)	
e1	1.800	2.000	0.071	0.079
L	0.300	0.600	0.012	0.024
r	0°	8°	0°	8°

Information furnished in this document is believed to be accurate and reliable. However, Jiangsu JieJie Microelectronics Co., Ltd. assumes no responsibility for the consequences of use without consideration for such information nor use beyond it. Information mentioned in this document is subject to change without notice, apart from that when an agreement is signed, Jiangsu JieJie complies with the agreement.

Products and information provided in this document have no infringement of patents. Jiangsu JieJie assumes no responsibility for any infringement of other rights of third parties which may result from the use of such products and information. This document supersedes and replaces all information previously supplied.

 is a registered trademark of Jiangsu JieJie Microelectronics Co., Ltd.

Copyright © 2023 Jiangsu JieJie Microelectronics Co., Ltd. All rights reserved.